

RCIM-173WX3A

Rack mount display, Console Drawer, Triple/Dual 17.3" LCD Displays



Features

- 17.3" Rack Mount Triple LCD Display Console Drawer, 1.5u Height
- 1920 x 1080 Ultra high resolution
- Triple HDMI & VGA Ports
- Front 2xUSB, Rear 1xUSB 2.0 Type A, Sharing USB peripheral Device for computer (ex, flash disk, hard driver, KB/Mouse)
- 96-key keyboard with touch pad mouse
- USB 2.0 Keyboard & Mouse
- Build in 2x 2 watts speakers
- Self-locking and auto release rails

Specifications

LCD characteristics

Display Type	17.3" Wide Screen LCD
Resolution	1920 x 1080
Max.color	16.7 M
Luminance	500 cd/m2
View Angle	170°(H) , 170°(V)
Contrast Ratio	1000:1
Response Time	8 ms
Backlight Life	50,000hrs

System & I/O

LCD displays	Triple LCD Displays
Input Signal	3 x HDMI, 3x VGA
Audio	1 x 3.5mm Audio jack
KB/Mouse interface	1 x USB2.0 for Keyboard & Mouse
Keyboard	96-keys and touchpad
USB HUB	Front x2 & Rear x 1 USB 2.0 for USB Peripheral Device
Rack Depth	600mm to 900mm rack-mount cabinet front rails to rear rails
Speaker	2x Speakers

Available Options

Power options	48V, 24V or 12V DC Power
Input signal	Composite Video input

Mechanical and Environmental

Construction	Heavy duty steel alloy chassis
--------------	--------------------------------

Operate temperature	-10~ 60°C (-14~140°F)
Storage temperature	-20~ 70°C (-4 ~ 158°F)
Storage humidity	5%~ 95%, non-condensing
Anti-Vibration	17HZ-500 HZ 1G PTP
Anti-Shock	1G / peak(11m sec)
Dimensions (WxHxD)	450x67x 535 mm
Weight	Net: 18.9 kg , Gross:23 kg

Power Supply

Standard	100-240V AC 50/60Hz via IEC Type power cord
DC Power (Optional)	Wide Range 9~36V DC input

Ordering information

Model	Descriptions
RCIM-173WX3A	Rack mount display, 1.5U, LCD console Drawer, Triple 17.3" LCD displays, 1x Keyboard & touchpad, 100-240V AC IEC Type power cord
RCIM-173WX3D	Rack mount display, 1.5U, LCD console Drawer, Triple 17.3" LCD displays, 1x Keyboard & touchpad, 9~36V DC input
RCIM-173WX2A	Rack mount display, 1.5U, LCD console Drawer, Dual 17.3" LCD displays, 1x Keyboard & touchpad, 100-240V AC IEC Type power cord
RCIM-173WX2D	Rack mount display, 1.5U, LCD console Drawer, Dual 17.3" LCD displays, Keyboard & touchpad, 9~36V DC input

RCIM-173WX3A

Pictures & Views



Dimensions Diagram(RCIM-173WX3)

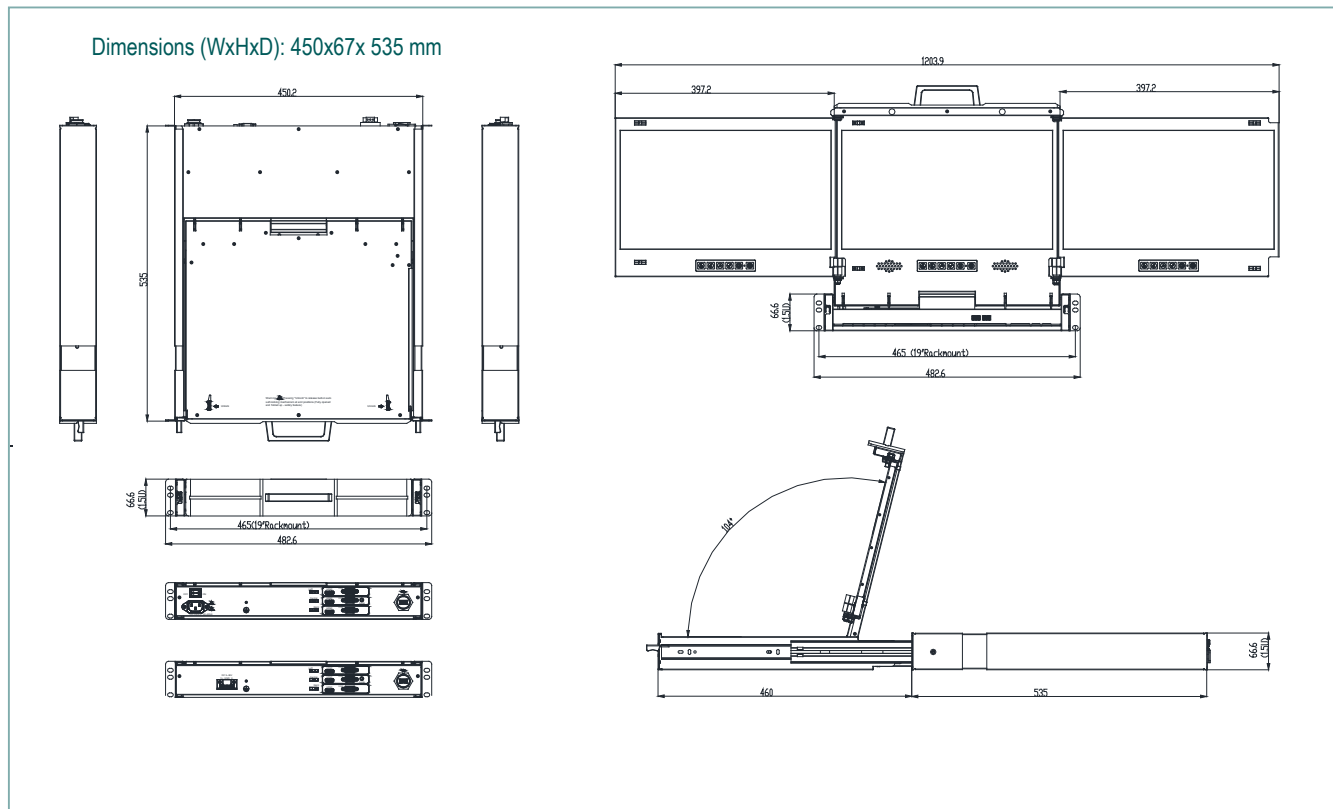

Rack Mount